

COOLING SYSTEM

	Page
COOLING SYSTEM CIRCUIT	7-2
WATER PUMP CUTAWAY VIEW	7-3
WATER PUMP	7-4
WATER PUMP(With Temperature Controlled Coupling)..	7-9
RADIATOR	7-14
THERMOSTAT	7-14

COOLING SYSTEM CIRCUIT

Fig. 7-1

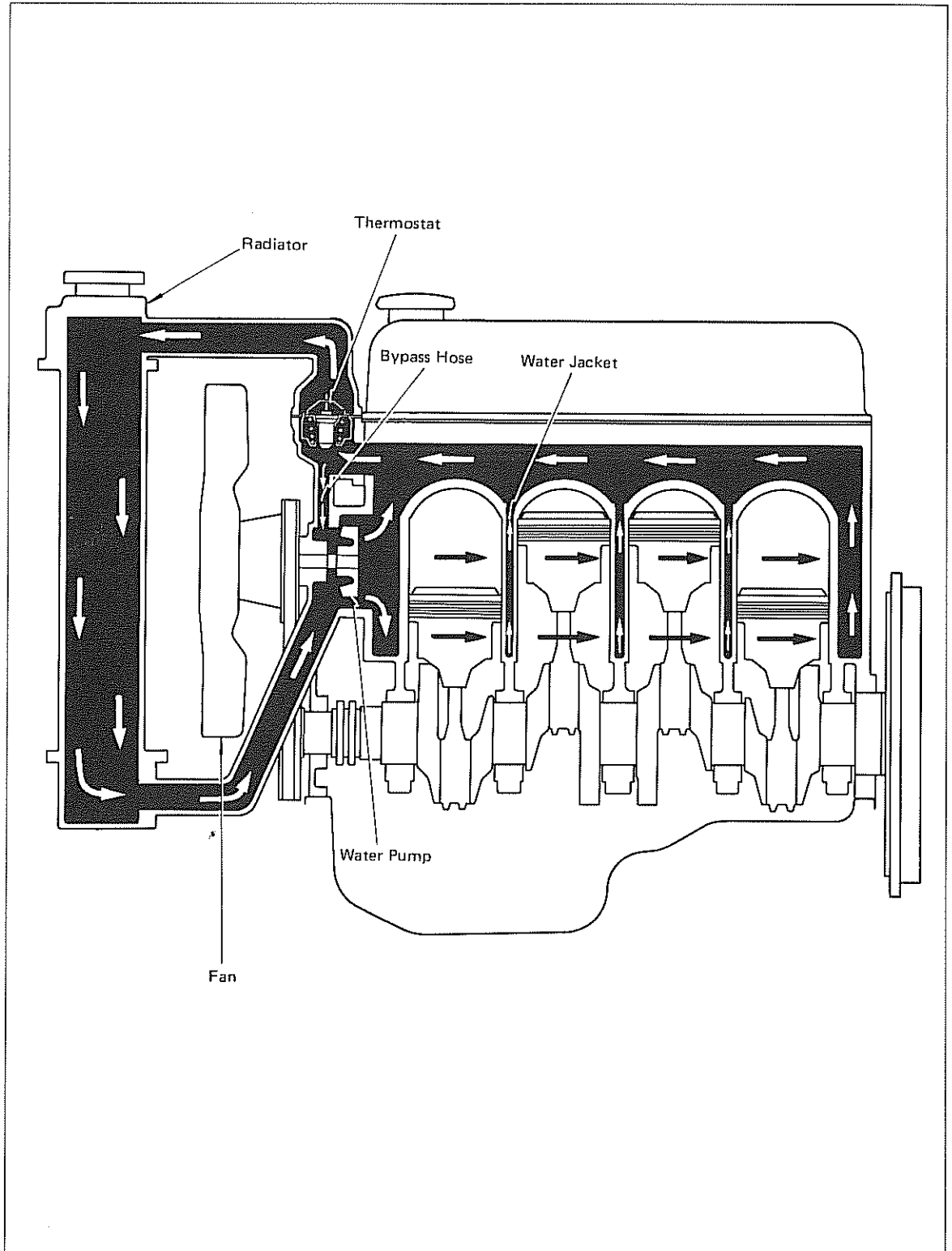

WATER PUMP CUTAWAY VIEW

Fig. 7-2

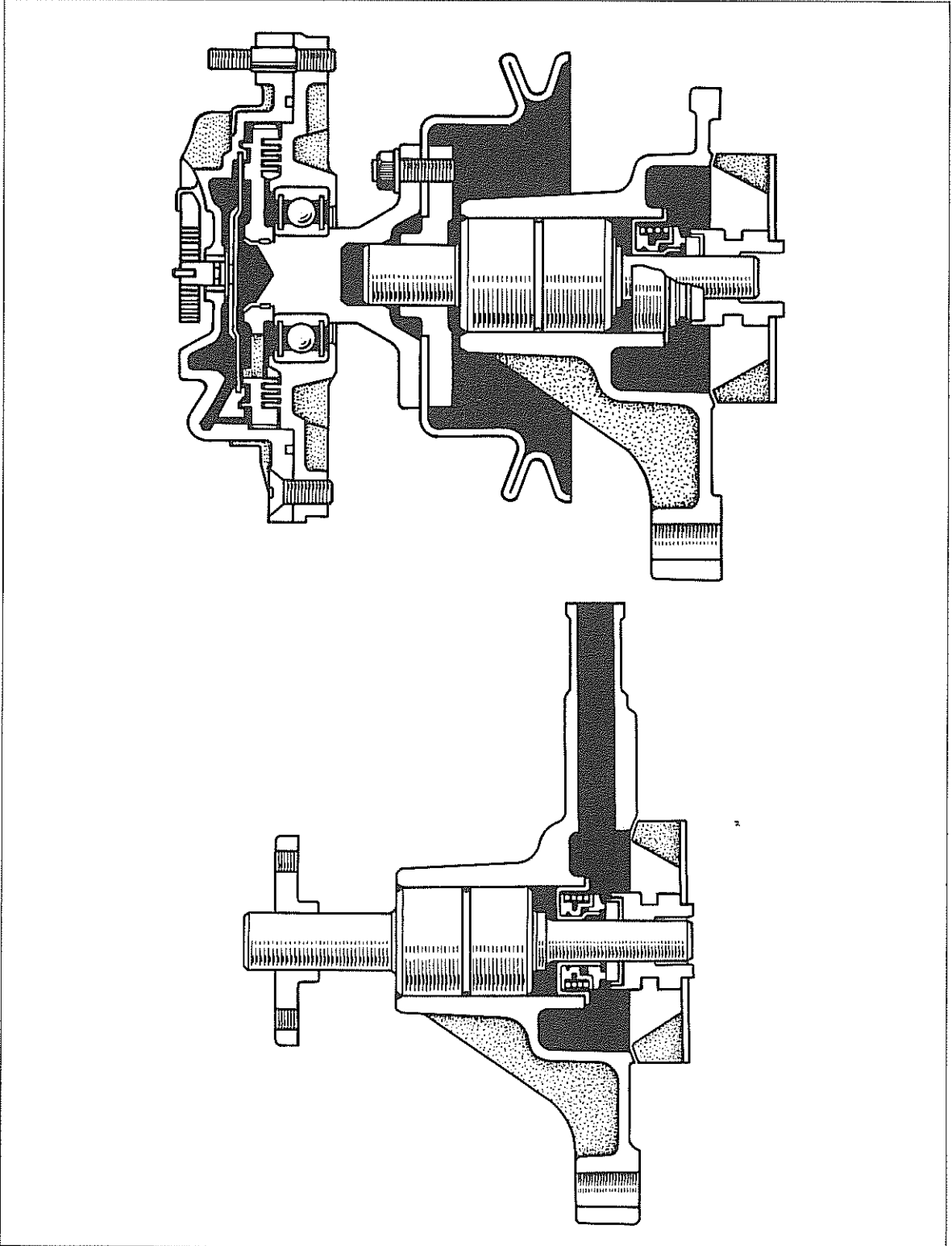

WATER PUMP DISASSEMBLY

Disassemble the parts in the numerical order shown in the figure.

Fig. 7-3

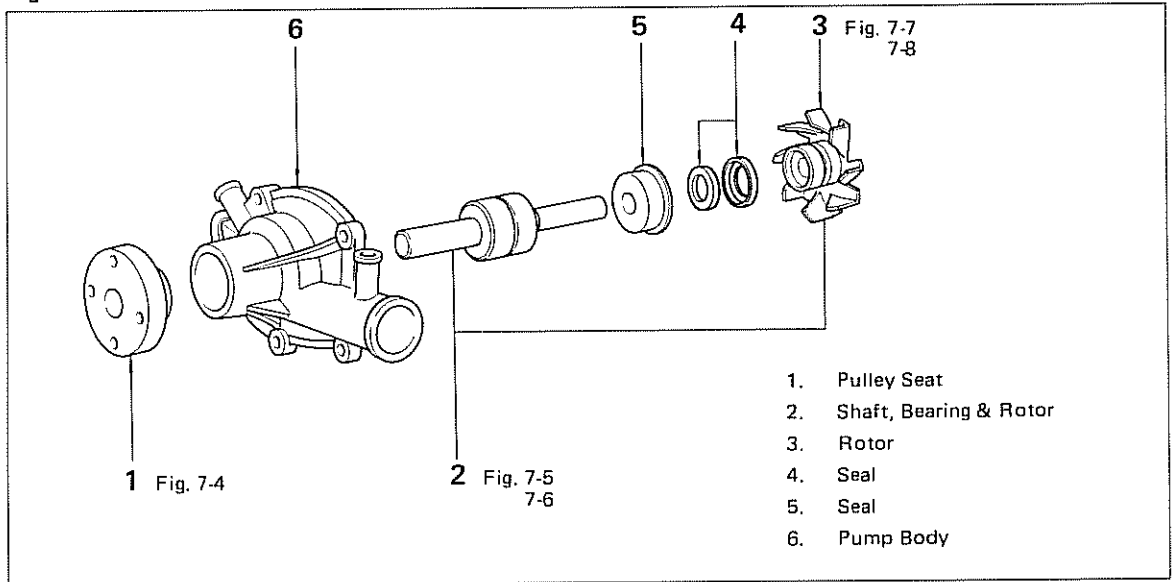
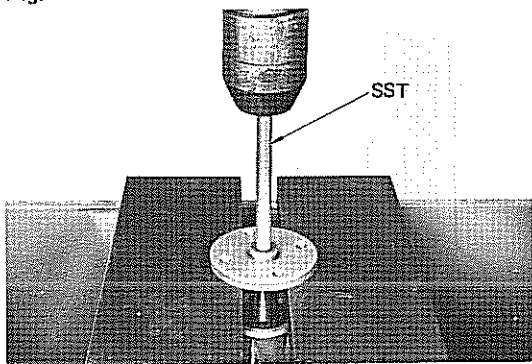
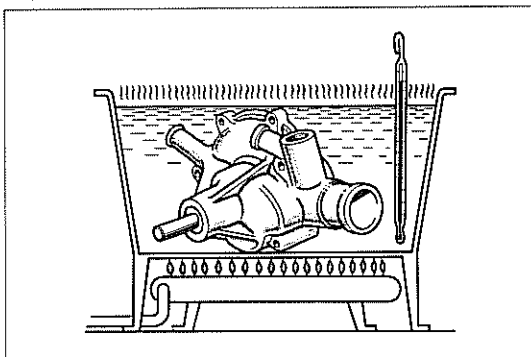

Fig. 7-4



While supporting the pulley seat, press out the shaft with SST.
SST[09236-36010]

Fig. 7-5



Heat the water pump body to about 80°C (176°F).

Fig. 7-6

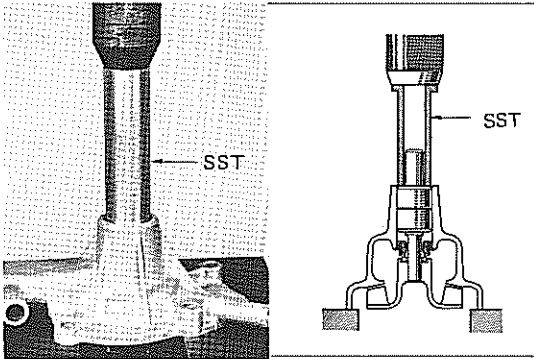

Press out the bearing together with the rotor using SST.
SST[09236-28011]

— Note —

Always replace the seal set when assembling.

Fig. 7-7

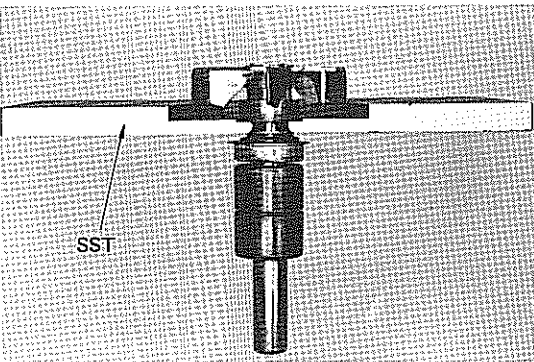

Support the rotor with SST as shown in the figure.
SST[09236-28011]



Fig. 7-8

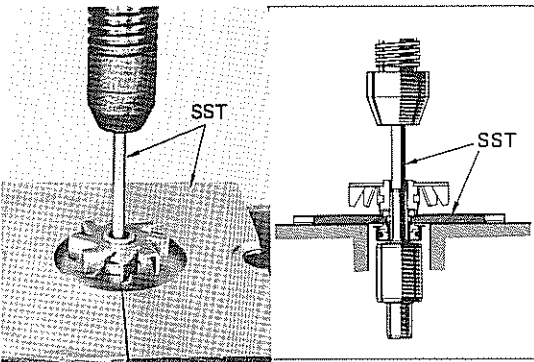

Press out the shaft with SST.
SST[09236-36010]

ASSEMBLY

Assemble the parts in the numerical order shown in the figure.

Fig. 7-9

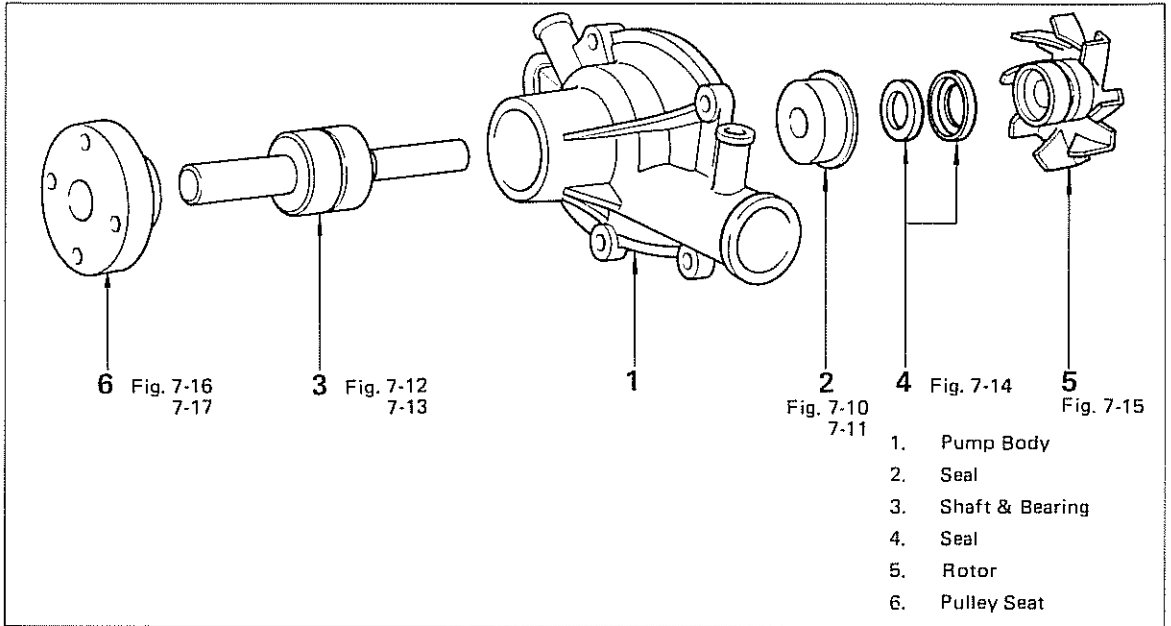
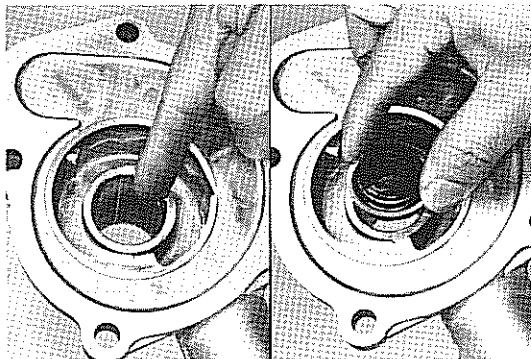
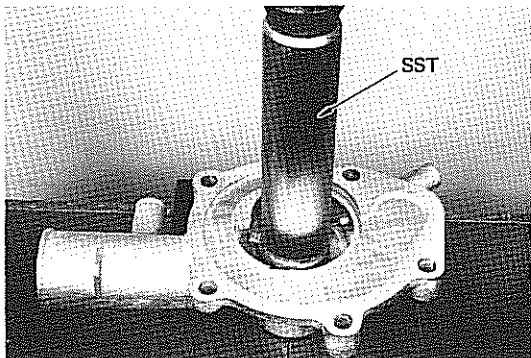

Fig. 7-10



Apply liquid sealer on the pump body.

Fig. 7-11



Press in the seal set into the pump body with SST.

SST[09236-36010]

Fig. 7-12

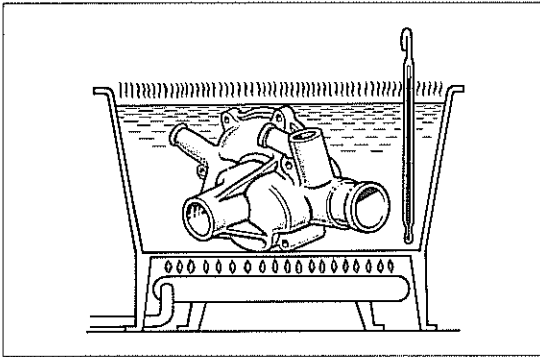

Heat the pump body to about 80°C (176°F).

Fig. 7-13

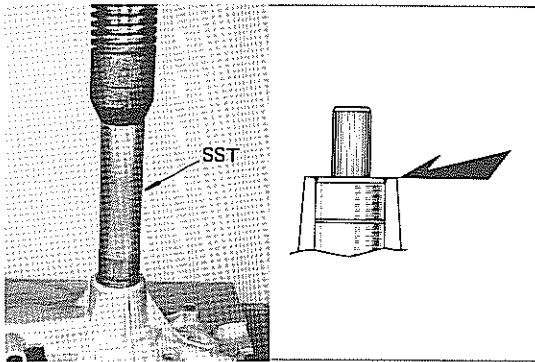

Press in the bearing with SST.
SST [09236-36010]

– Note –
Bearing end face should be flush with the body top surface.

Fig. 7-14

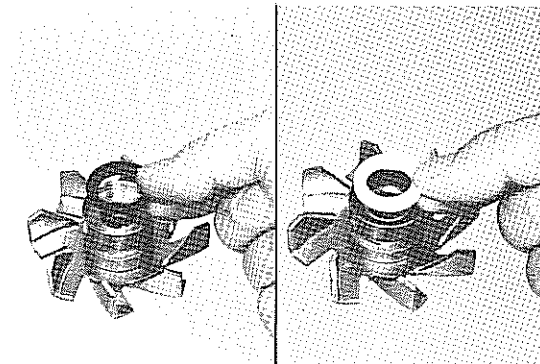

Install the seal set into the rotor:

Fig. 7-15

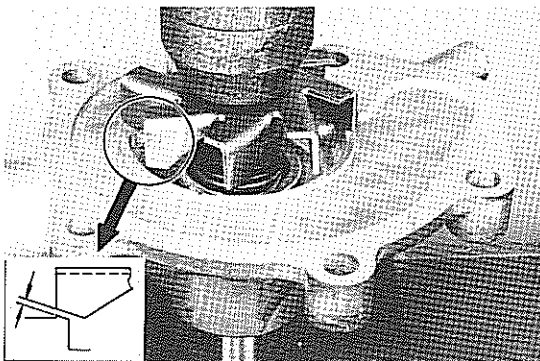

Press in the rotor.

Rotor body clearance: 1 mm
(0.04 in.)

Fig. 7-16

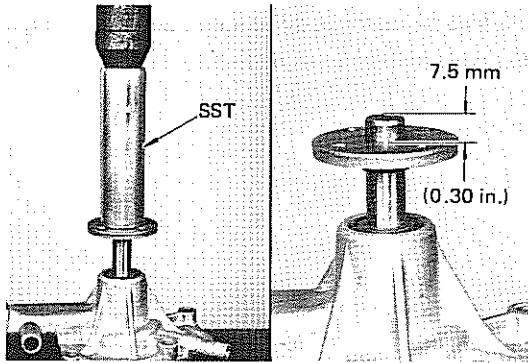

Press in the pulley seat with SST as shown in the figure.
SST [09236-36010]

Fig. 7-17

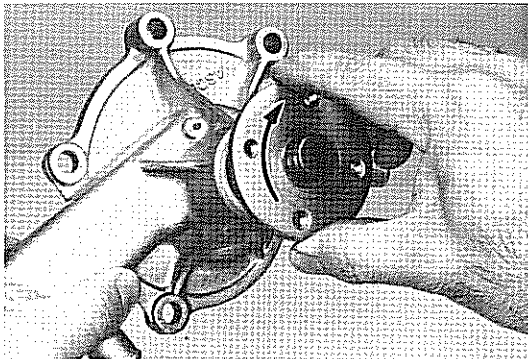

After assembly make sure the rotor rotates smoothly.

WATER PUMP (With Temperature Controlled Coupling)

DISASSEMBLY

Disassemble the parts in the numerical order shown in the figure.

Fig. 7-18

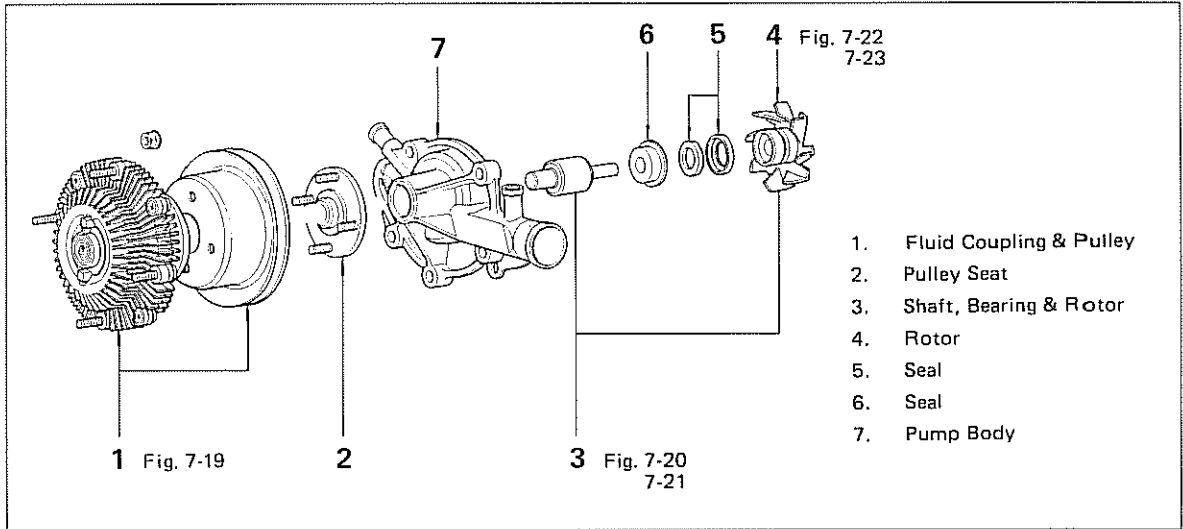
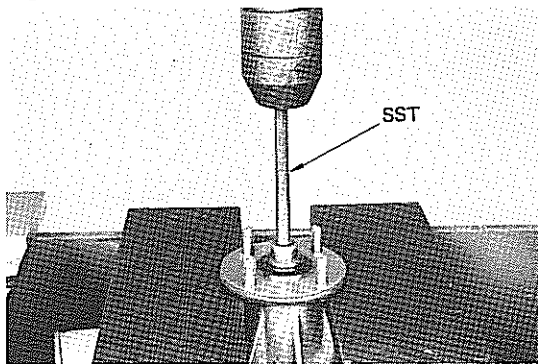
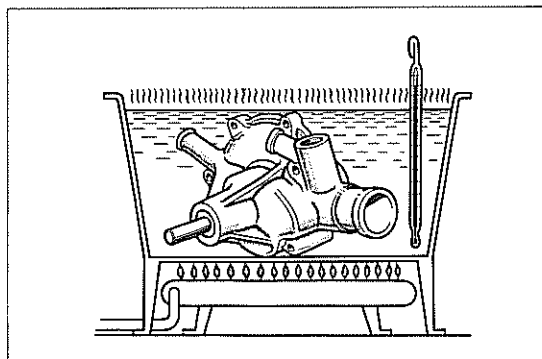

Fig. 7-19



While supporting the pulley seat, press out the shaft with SST.
SST[09236-36010]

Fig. 7-20



Heat the water pump body to about 80°C (176°F).

Fig. 7-21

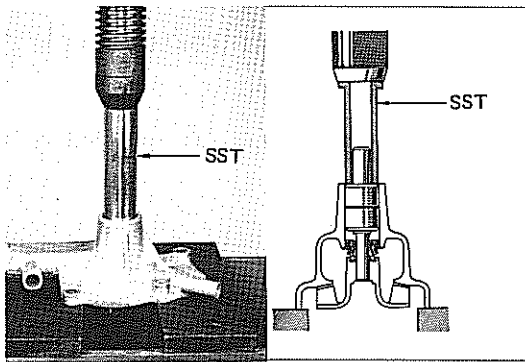

Press out the bearing together with rotor with SST.

SST[09236-28011]

– Note –

Always replace the seal set upon assembly.

Fig. 7-22

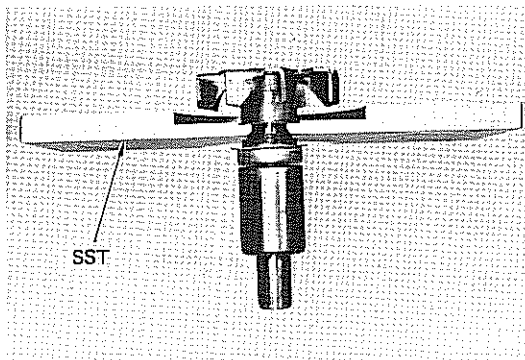

Support the rotor with SST as shown in the figure.

SST[09236-28011]

Fig. 7-23

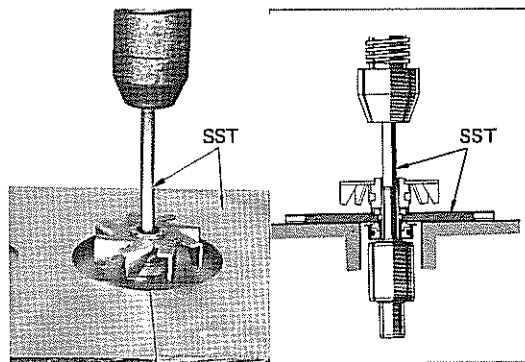

Press out the shaft with SST.

SST[09236-36010]

ASSEMBLY

Assemble the parts in the numerical order shown in the figure.

Fig. 7-24

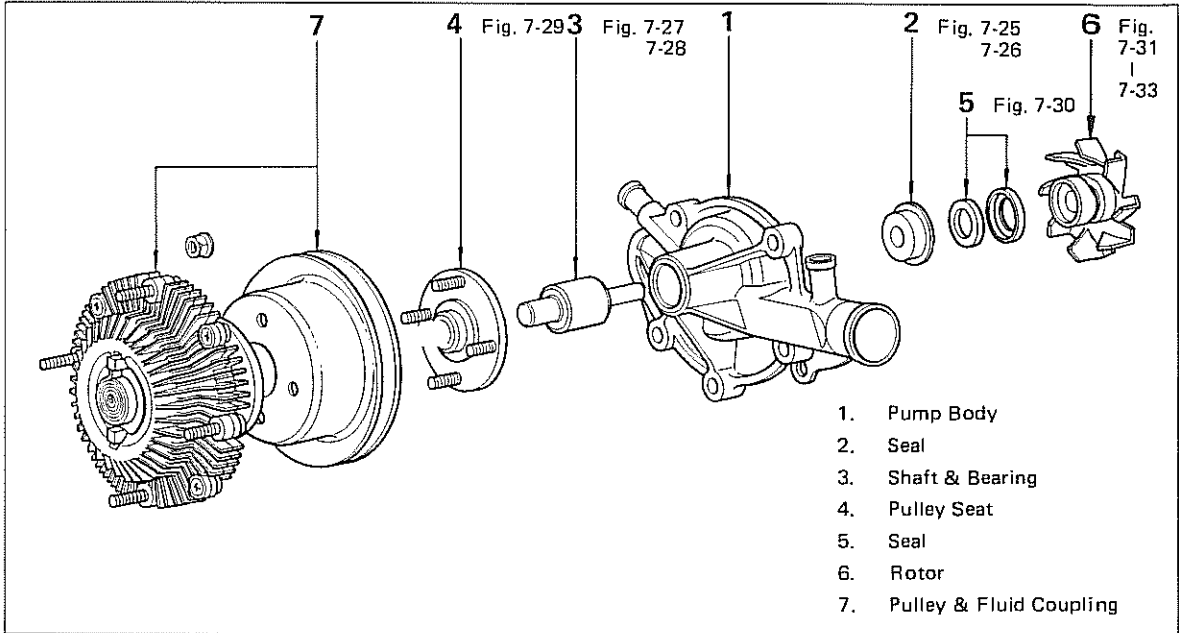
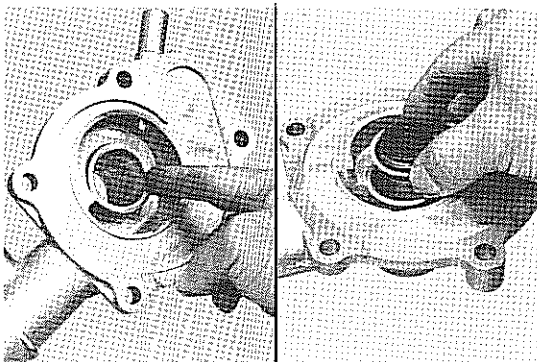
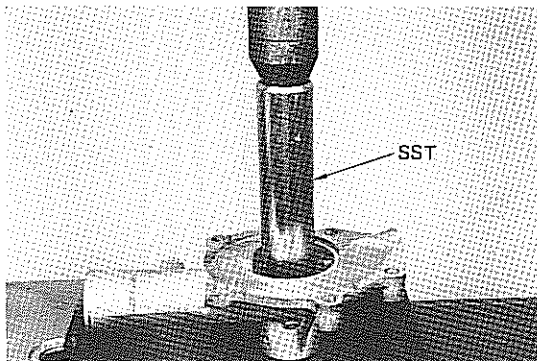

Fig. 7-25



Apply liquid sealer on the pump body.

Fig. 7-26



Press in the seal set into the pump body.

Fig. 7-27

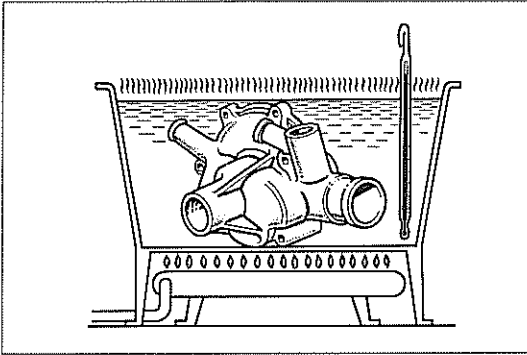

Heat the pump body to about 80°C (176°F).

Fig. 7-28

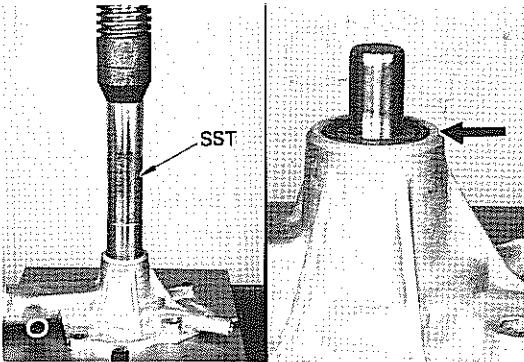

Press in the bearing with SST.
SST[09236-28011]

– Note –

Bearing end face should be flush with the body top surface.

Fig. 7-29

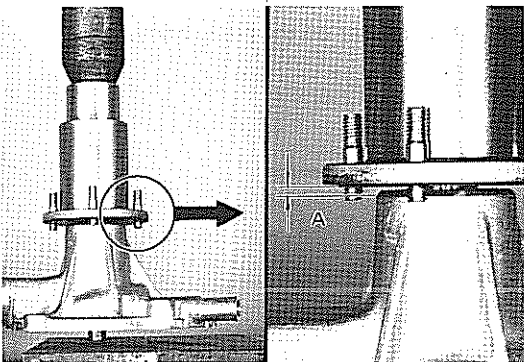

Press in the pulley seat until the A clearance about 2.0 mm (0.08 in.).

Fig. 7-30

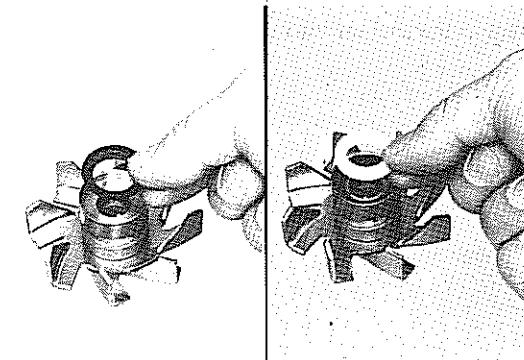

Install the seal set into the rotor.

Fig. 7-31

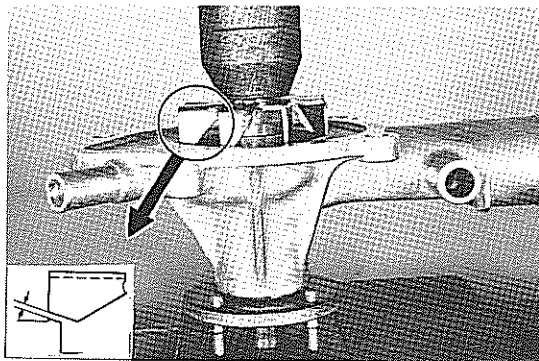

Press in the rotor.

Rotor body clearance: 1.0 mm
(0.04 in.)

Fig. 7-32

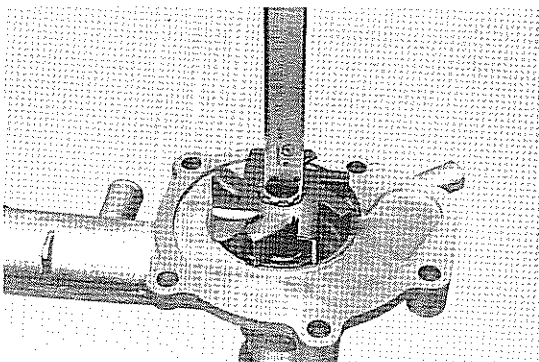

After assembly check the shaft depth.

Shaft depth: 13 mm
(0.5 in.)

Fig. 7-33

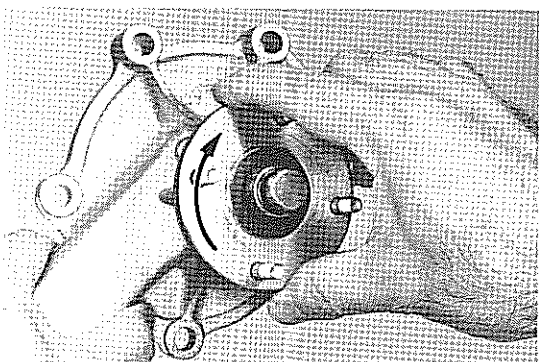

After assembly make sure the rotor rotates smoothly.

Fig. 7-34

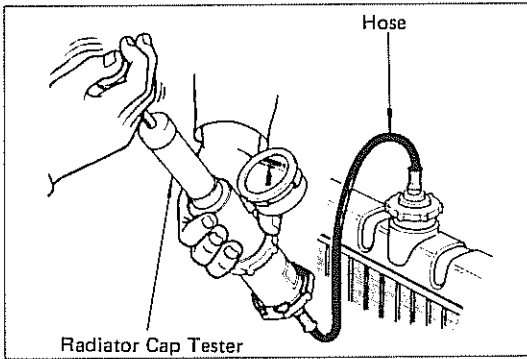

RADIATOR INSPECTION

1. Install the radiator cap tester to the radiator, apply pressure and check for leakage in the cooling system under normal operating temperature.

**Applicable pressure: 1.2 kg/cm²
(17 psi)**

Fig. 7-35

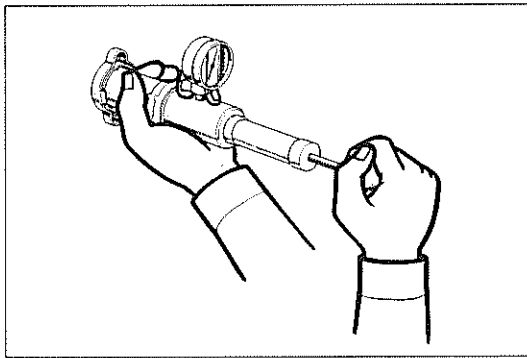

2. Check pressure sealing and vacuum relief valve operation.

Valve opening pressure:
**STD 0.75 – 1.05 kg/cm²
(10.7 – 14.9 psi)**

**Limit 0.6 kg/cm²
(8.5 psi)**

3. If readings are not within acceptable limits, replace radiator cap.

Fig. 7-36

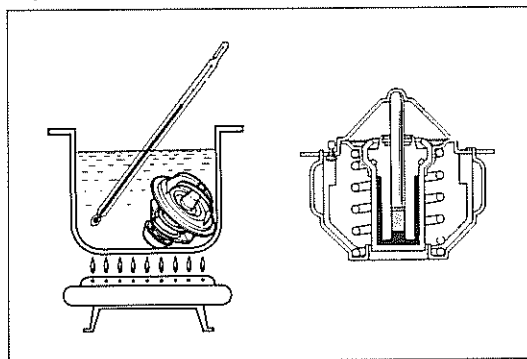

THERMOSTAT INSPECTION

1. Immerse the thermostat in water, and check the valve opening temperatures by heating the water gradually.
2. Replace the thermostat if the valve remains open at normal temperature or is not very tight when fully closed.

**Valve starts to open at 80.5 – 83.5°C
(177 – 182°F).**

Fig. 7-37

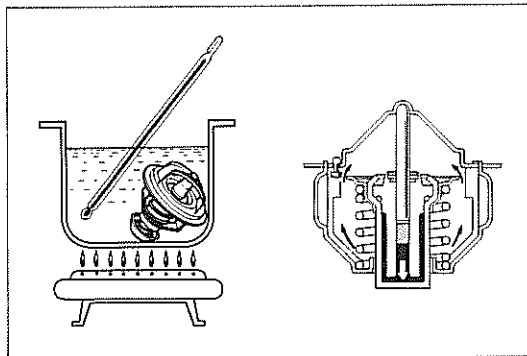

**Valve opens by more than 10 mm
(0.4 in.) at 100°C (212°F).**